

# Additive manufacturing

---

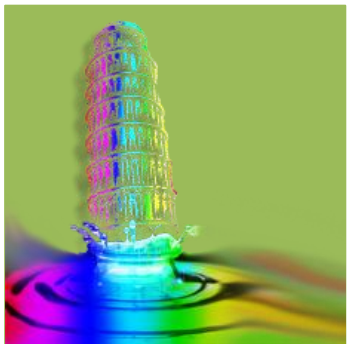

# + Question #1 07/10/2015

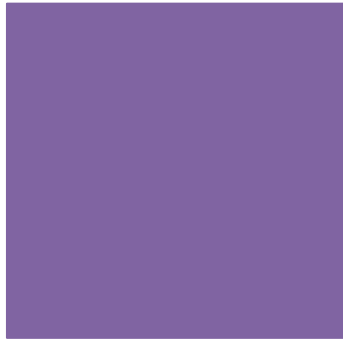

Which classes of materials can be processed with additive manufacturing technologies

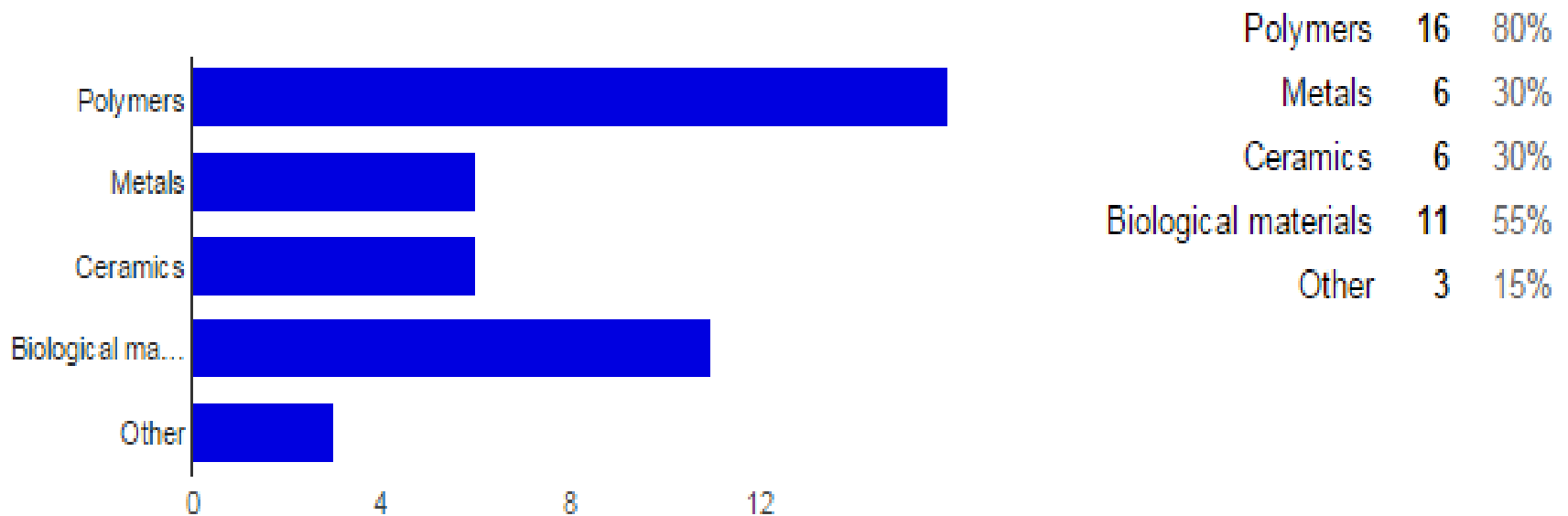

# + Question #2 07/10/2015



When Stereolithography (an additive manufacturing technology) was invented?

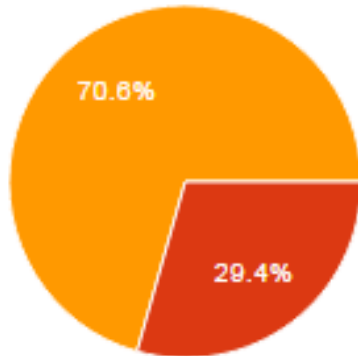

less than 10 years ago	0	0%
between 10 and 20 years ago	5	29.4%
more than 20 years ago	12	70.6%
Other	0	0%

# **MEDICAL APPLICATION OF RAPID PROTOTYPING**

# + Invisalign Orthodontic Aligners

- An aligner for orthodontic use manufactured using a combination of rapid tooling and thermoforming.



# + Surgery



# + Surgery



# + Surgery

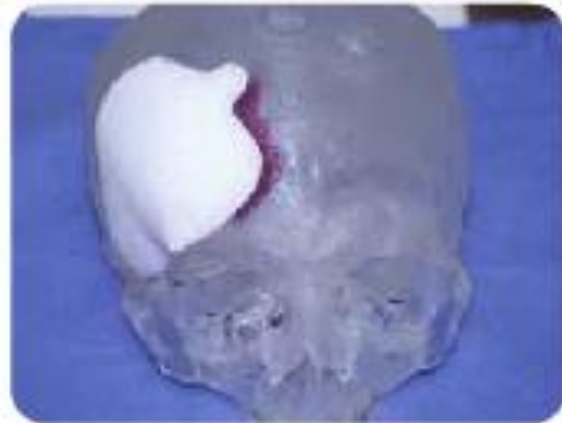



# + Surgery



# + Tissue Engineering - Biofabrication

- Living cells are extracted from patients and seeded onto a carrier (scaffold) which accomodates and guides the growth of new cells in 3D within laboratory environment.



# + Tissue Engineering - Biofabrication

- STL Data produced from Micro-CT scan data
- Multiple specimens of identical structure can be made, reducing samples variations.

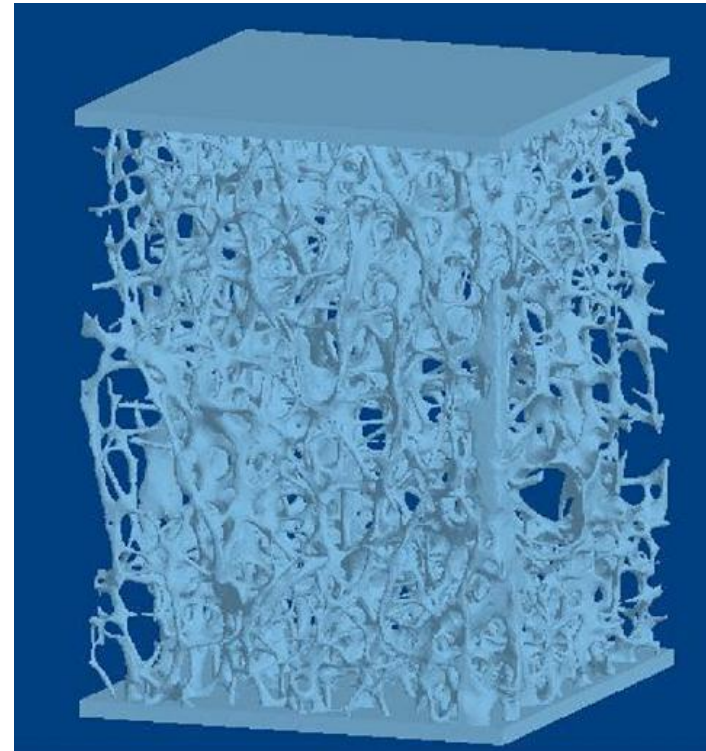

**OPEN QUESTION**

# + Open questions



- WHICH ARE THE INTELLECTUAL PROPERTY IMPLICATIONS OF LOW-COST 3D PRINTING?
- IS THE OPEN SOURCE 3-D PRINTING AN ENABLING TECHNOLOGY FOR SELF-DIRECTED SUSTAINABLE DEVELOPMENT?
- CAN A 3D PRINTED ORGAN BE PATENTED?

# Software for Additive manufacturing

---

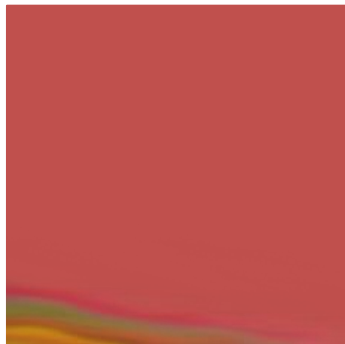
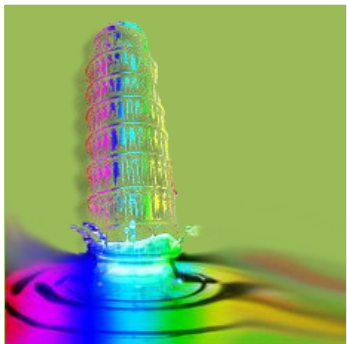

# + Additive manufacturing

## Process Flow

- Solid Modelling
- Tessellation/Generation of STL file
- Support Generation
- “Slicing” of the Model
- Model Physical Buildup
- Cleanup and Post Curing
- Surface Finishing



# + from idea to design

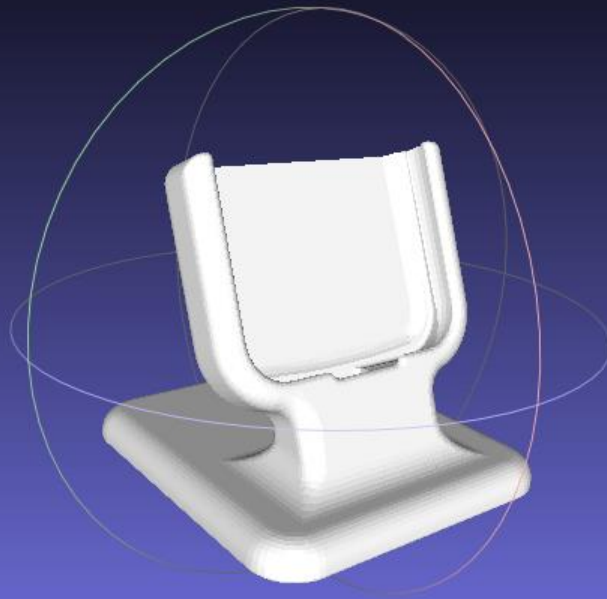



# + from idea to design

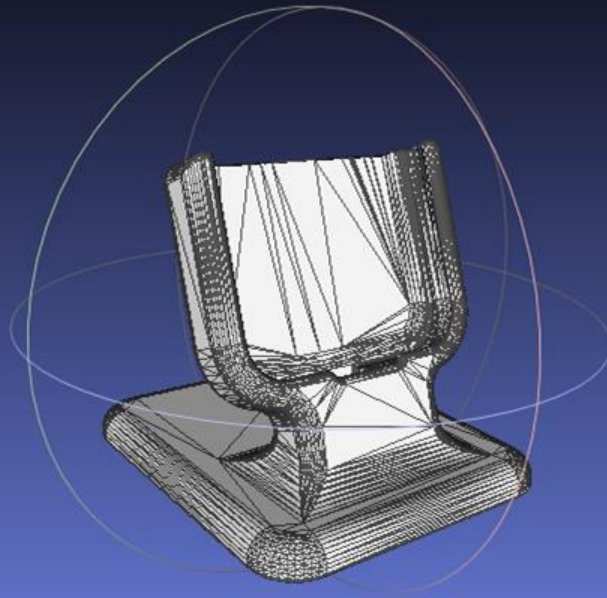

# + from design to object

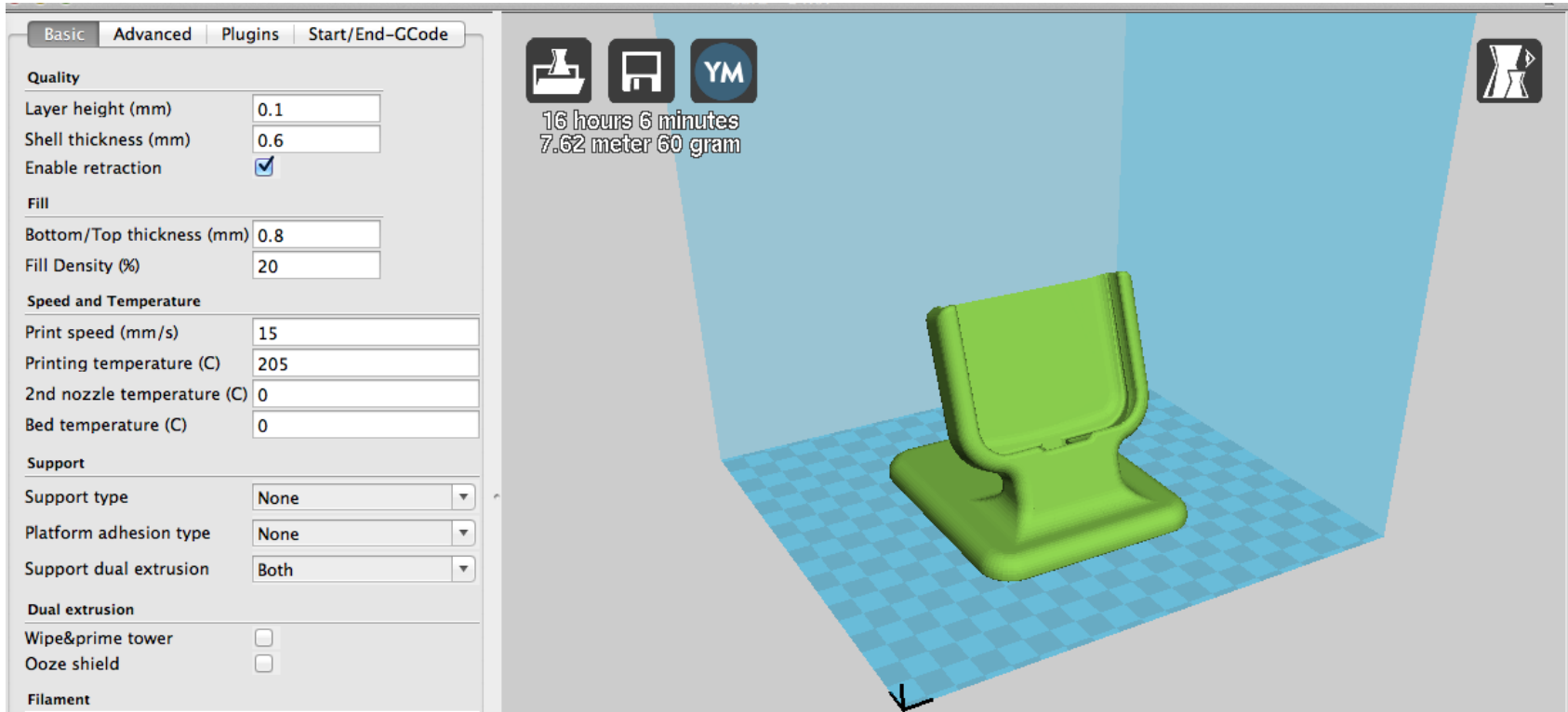

The screenshot displays a 3D printing software interface. On the left is a settings panel with the following sections and values:

- Quality**
  - Layer height (mm): 0.1
  - Shell thickness (mm): 0.6
  - Enable retraction:
- Fill**
  - Bottom/Top thickness (mm): 0.8
  - Fill Density (%): 20
- Speed and Temperature**
  - Print speed (mm/s): 15
  - Printing temperature (C): 205
  - 2nd nozzle temperature (C): 0
  - Bed temperature (C): 0
- Support**
  - Support type: None
  - Platform adhesion type: None
  - Support dual extrusion: Both
- Dual extrusion**
  - Wipe&prime tower:
  - Ooze shield:
- Filament**

On the right, a 3D view shows a green chair model on a blue and white checkered floor. Above the model, the following statistics are displayed:

- 16 hours 6 minutes
- 7.62 meter 60 gram

At the top of the interface, there are tabs for 'Basic', 'Advanced', 'Plugins', and 'Start/End-GCode'. In the top right corner, there are icons for a printer, a file, and a 'YM' logo, along with a printer status icon.

# + from design to object



# + from design to object



# + Additive manufacturing Process Flow



File



Description



Software

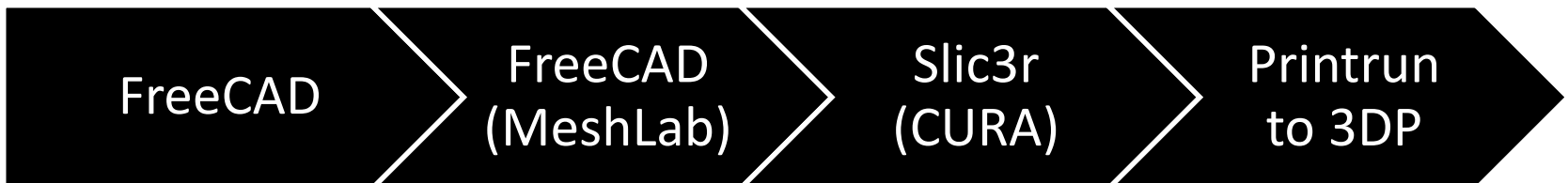

# + Additive manufacturing Process Flow



Image acquisition

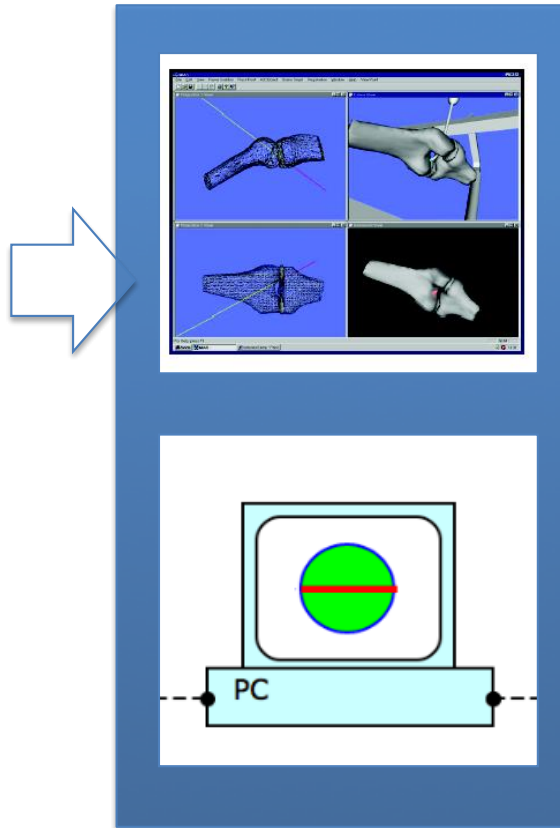

CAD/CAM system

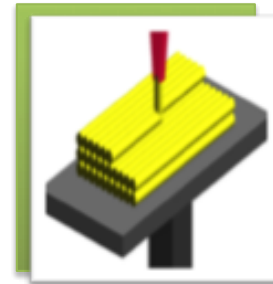

Direct writing

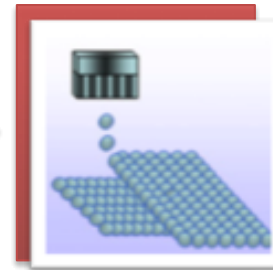

Inkjet based



**DATA SOURCE**

# + Data source

- Representation of a volume
  - CAD model
  - Instruments output
    - CT
    - RM





# + CAD model

Dimensions of CAD Elements	Elements	Type of CAD Model
0D	Point	Corner Model
1D	Line	Edge Model
2D	Surface	Surface Model
3D	Solid/Volume	Solid or Volume Model

Example 1

# **FROM MEDICAL IMAGES TO STL**

# + Segmentation

- Segmentation subdivides an image into its constituent regions or objects.
- The level to which the subdivision is carried out depends on the problem being solved



# + Software per l'analisi delle bioimmagini

- OsiriX ([www.osirix-viewer.com](http://www.osirix-viewer.com))
- 3DSlicer ([www.slicer.org](http://www.slicer.org))
- ImageJ ([rsb.info.nih.gov/ij](http://rsb.info.nih.gov/ij))
- MIPAV ([mipav.cit.nih.gov](http://mipav.cit.nih.gov))
- itk-SNAP ([www.itksnap.org](http://www.itksnap.org))



# + Image Analysis: OxiriX imaging software

- Advanced open-source DICOM PACS workstation
- Image processing
- Better communication with surgeons



# + Geometry extraction

- From original CT DICOM image to final volume
  - Semi-automatic procedure
  - Positive results in 95% of cases

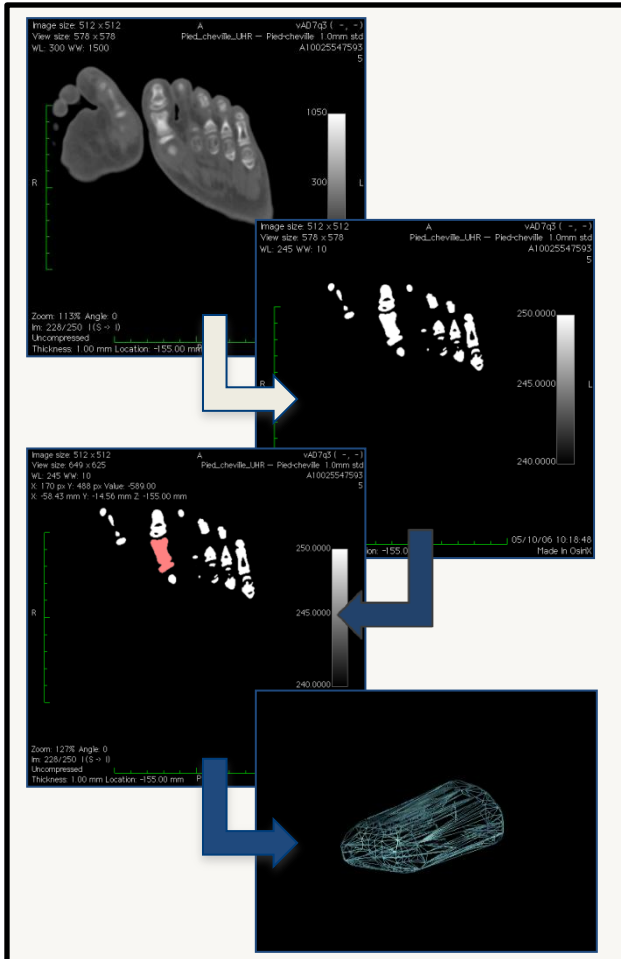

# + Osirix Plugins: edge preserving smoothing

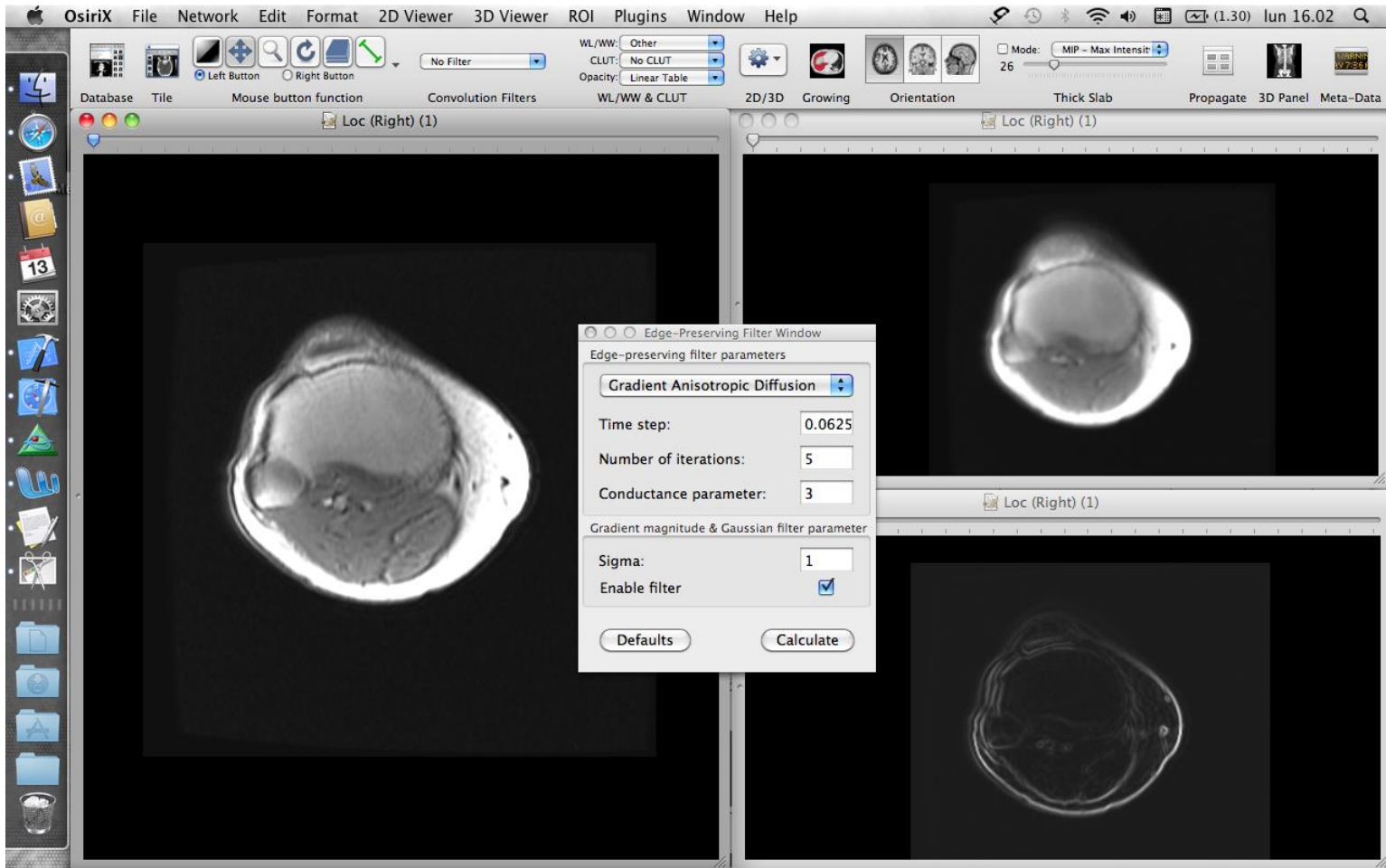

# + Osirix Plugins: Level-Set segmentation

- Two algorithm
  - Shape detection
  - Geodesic Active Contours
- Evolution based on
  - Propagation
  - Curvature
  - Advection
- Programming principles

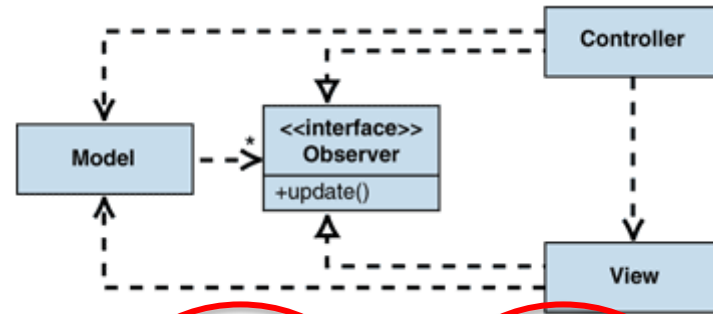

$$\frac{d}{dt}y = -a\mathbf{A}(\mathbf{x}) \cdot \nabla y - bP(\mathbf{x})|\nabla y| + g\mathbf{Z}(\mathbf{x})k|\nabla y|$$

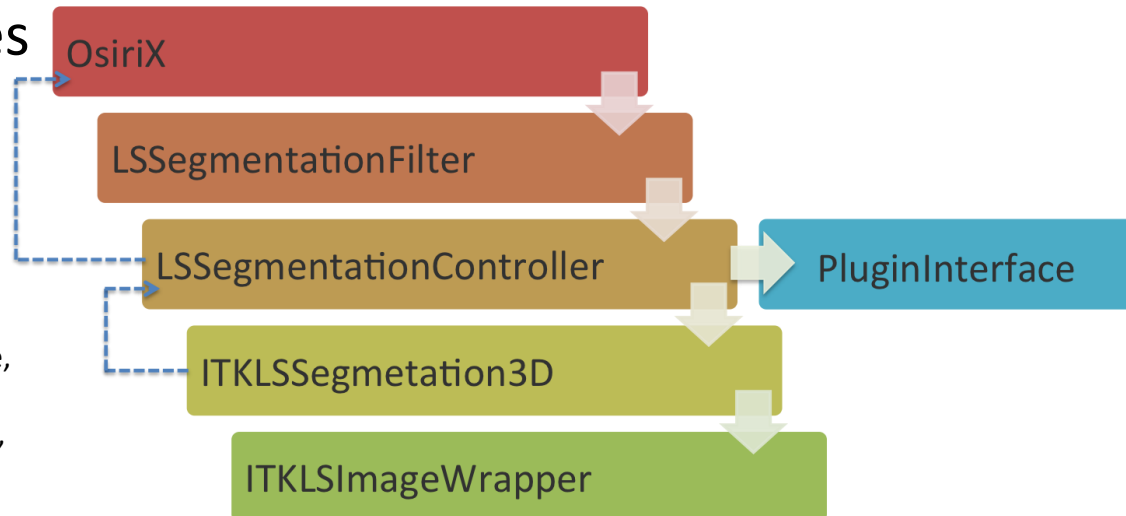



# + Osirix Plugins: Level-Set segmentation

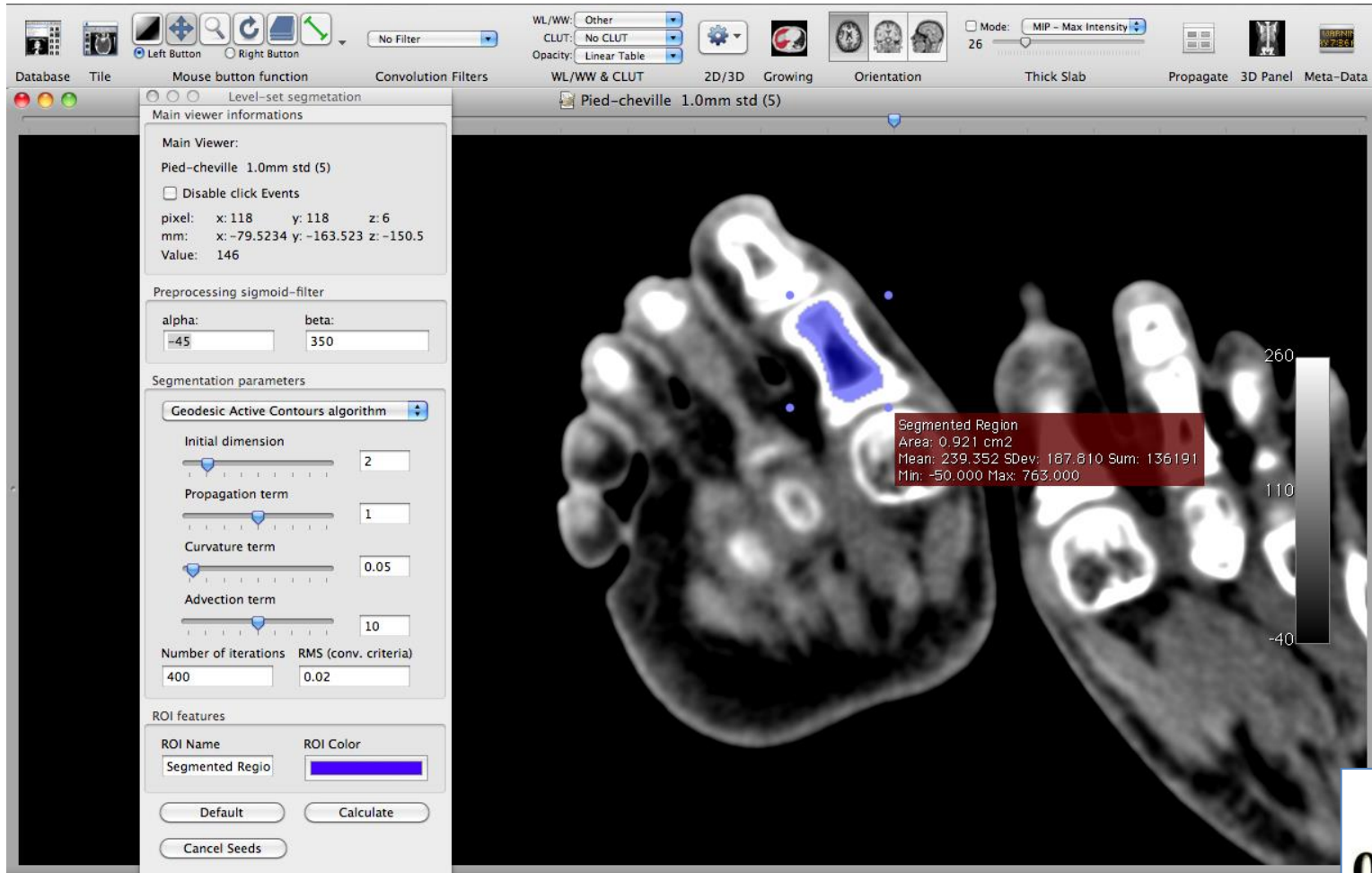

Use of 123DCatch

# **FROM 3D SCAN TO STL**







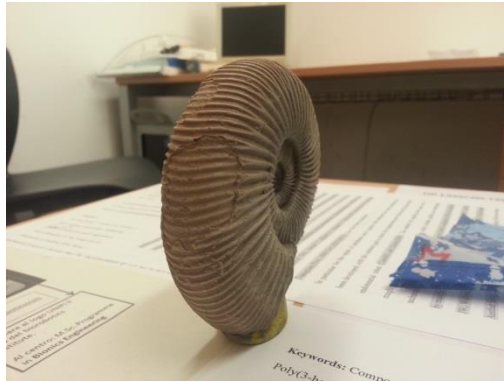

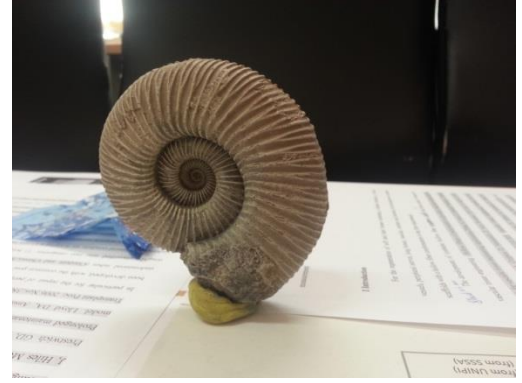



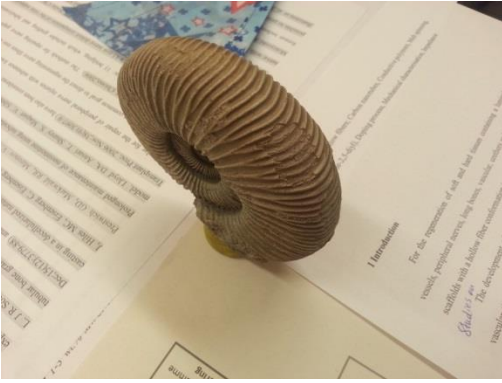
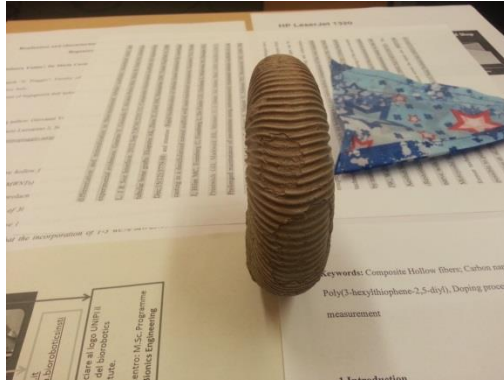







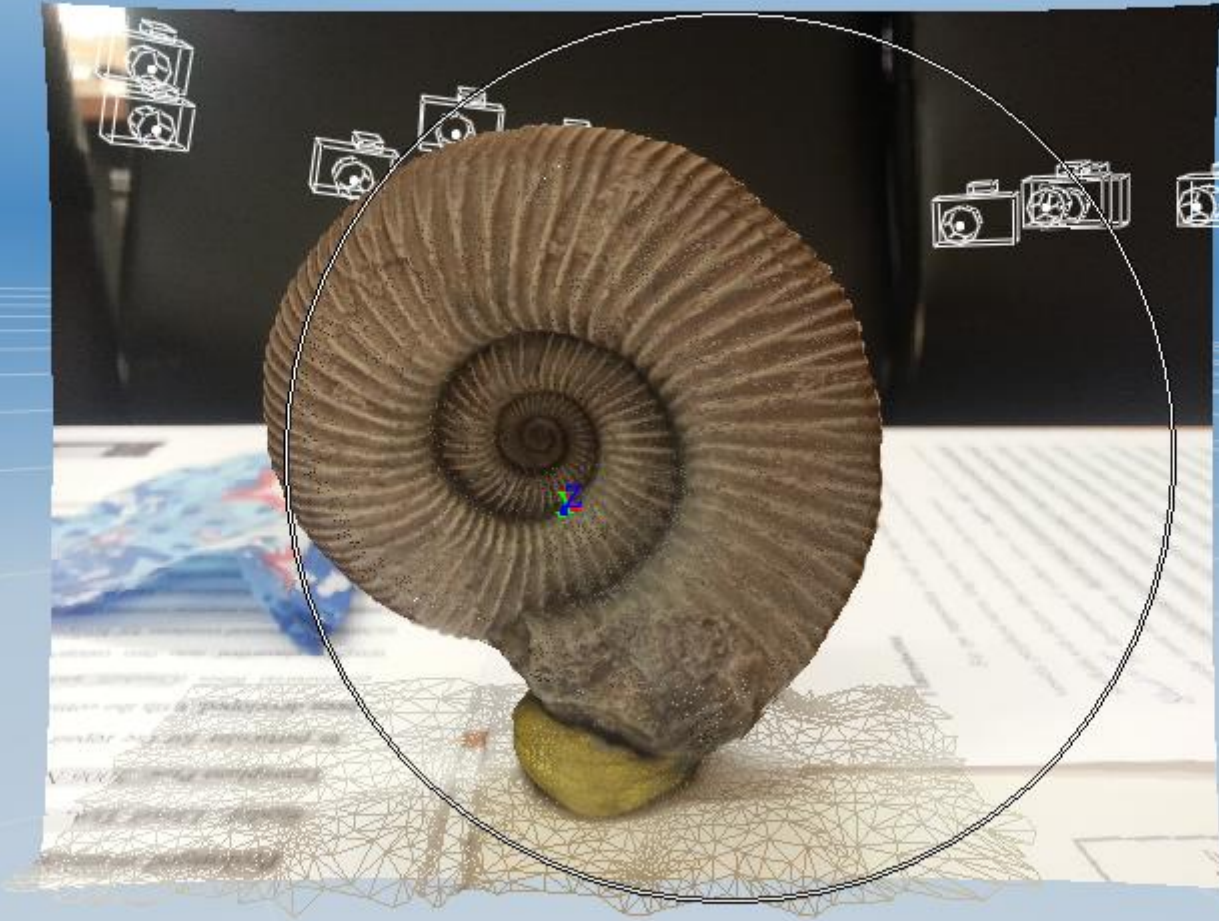

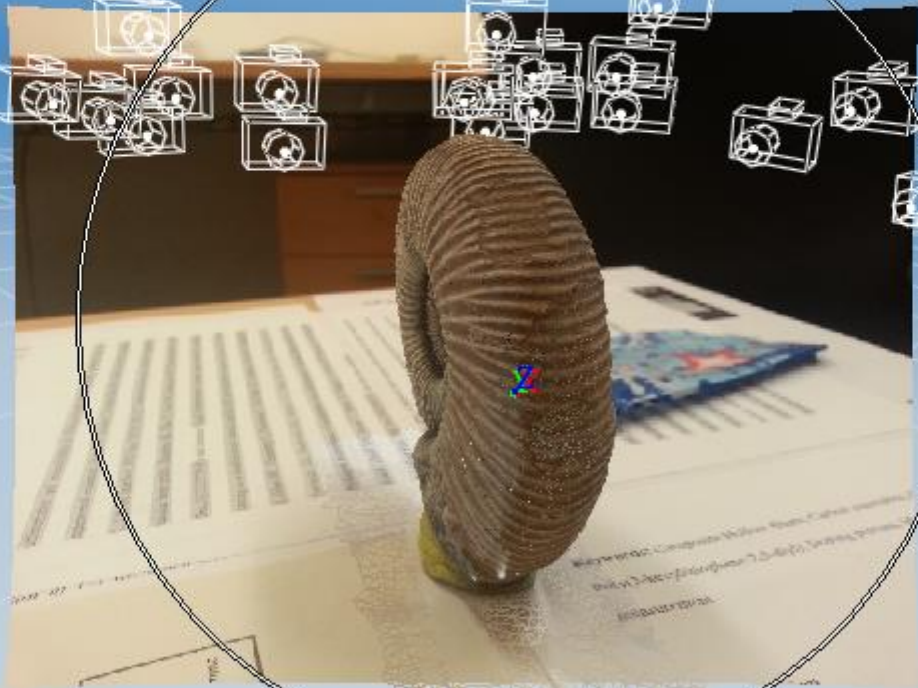



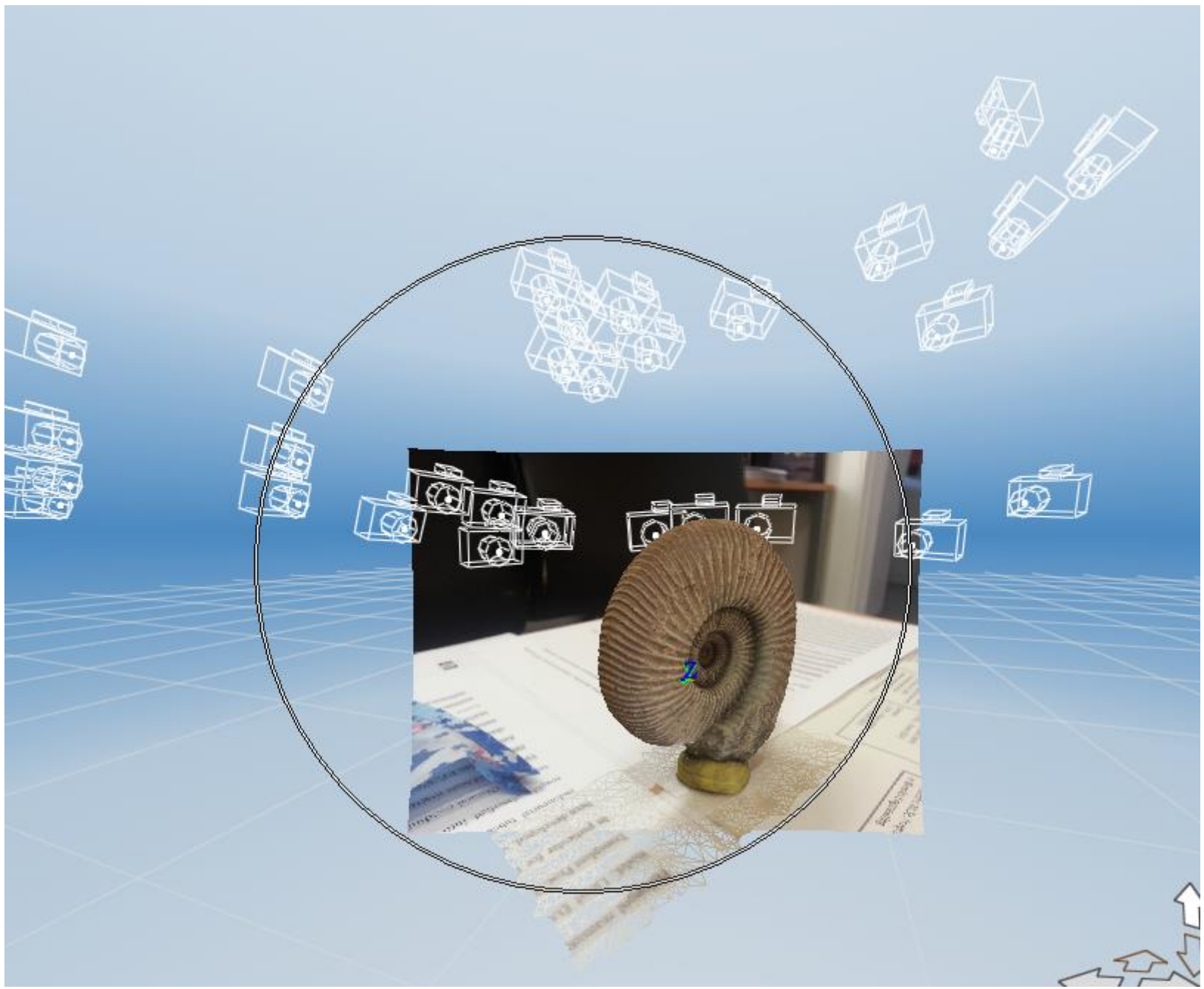



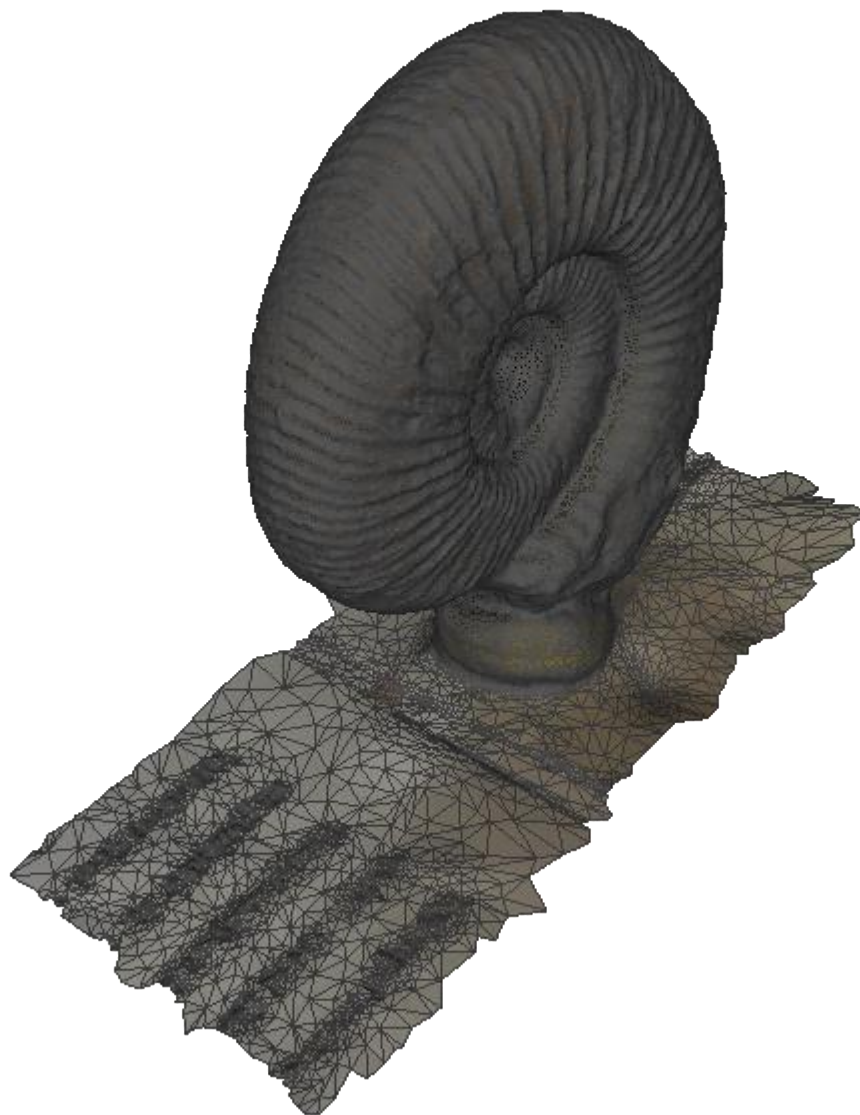



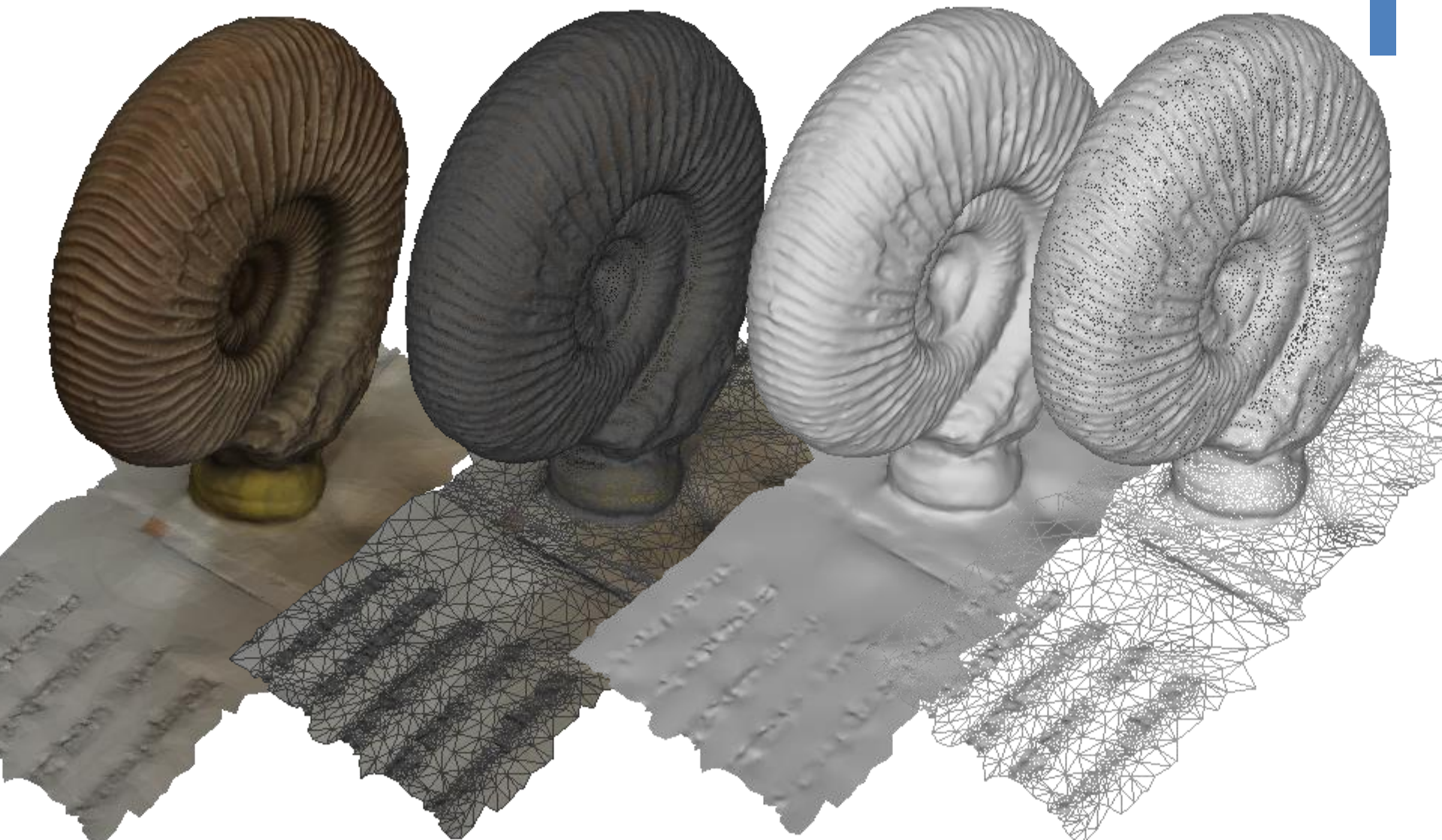







# **EXCHANGE FORMATS**

# + Stereolithography Interface

- Stereolithography was first commercial Solid Freeform Manufacturing (SFM) process, released in 80's by 3-D Systems
- 3-D Systems developed interface between CAD systems and their machine
- STL files (\*.stl) allow CAD systems to interface with 3-D system machines
- Virtually all subsequent SFM processes can use this same format (SFM industry standard)
- Many CAD programs now can export the \*.stl file for easy conversion from CAD to part

# + STL Files (\*.stl)

- STL files were based on a program called Silverscreen CAD
- Silverscreen CAD represent boundary with all surfaces being approximated by polygons or groups of polygons
- \*.stl files use triangles or groups of triangles to approximate surfaces
- Accuracy depends on the triangle sizes (Smaller facets produce a higher quality surface)
- Triangles assigned normal vectors for outward surface normal
- Parts are defined by representing all their bounding surfaces as faceted surfaces, using the triangular patches



# + STL Files (\*.stl)

- STL files describe only the surface geometry of a three dimensional object without any representation of color, texture or other common CAD model attributes.
- An STL file describes a raw unstructured triangulated surface by the unit normal and vertices (ordered by the r the triangles using a three Cartesian coordinate syst



# + Example of \*.stl Representation

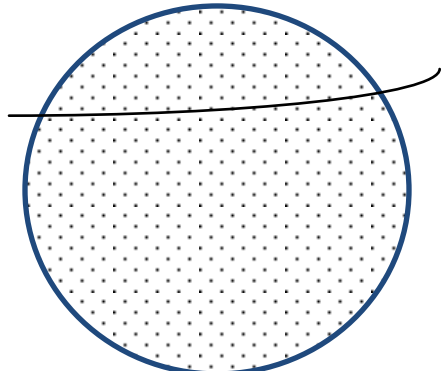

Representing  
a sphere

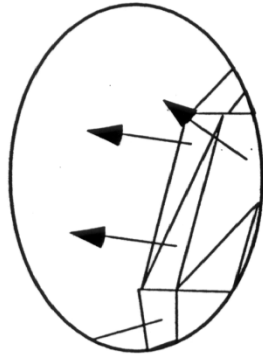
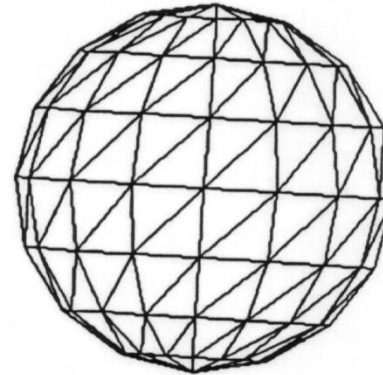

```
solid obj1
facet normal 1.457591e-01 -9.885599e-01 -3.877669e-02
  outer loop
    vertex 9.614203e+00 4.757629e+00 0.000000e+00
    vertex 7.875000e+00 4.501190e+00 0.000000e+00
    vertex 9.483117e+00 4.764183e+00 -6.598330e-01
  endloop
endfacet
facet normal 1.161178e-01 -9.870778e-01 -1.104267e-01
  outer loop
    vertex 9.483117e+00 4.764183e+00 -6.598330e-01
    vertex 7.875000e+00 4.501190e+00 0.000000e+00
    vertex 9.109818e+00 4.782848e+00 -1.219212e+00
  endloop
endfacet
facet normal 6.134766e-02 -9.843393e-01 -1.652652e-01
```

# + Example of \*.stl Representation

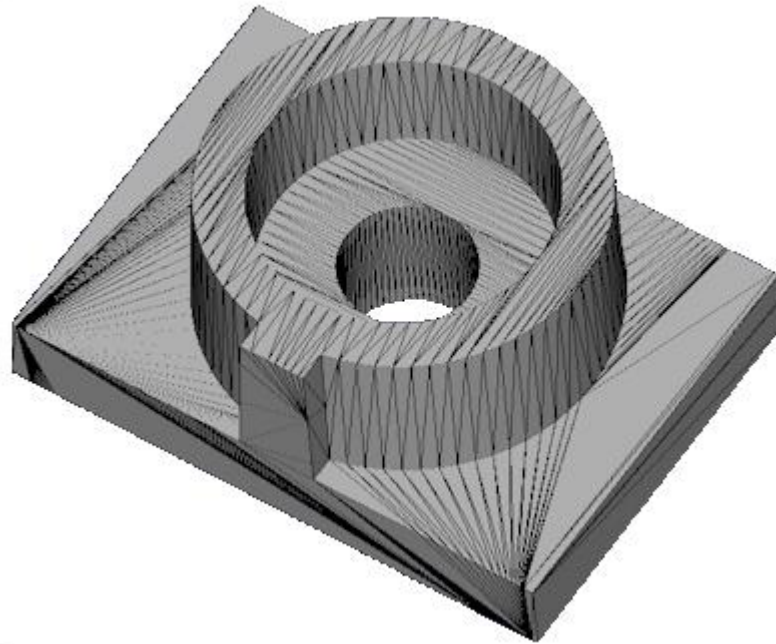

# + Existing Formats (1/2)



- 3D PDF
  - Proprietary, closed
- ISO 14649 (STEP-NC)
  - Mostly for NC control, G-Code
- STEP / IGES, SAT, Parasolid
  - Too complex, missing features e.g. no mesostructure
- X3D VRML
  - Mesh, color, texture, lighting

All: no provision for AM, e.g. materials, internal structure



# + Existing Formats (2/2)



- PLY
  - 3D Scanner data
- 3DS
  - Limited mesh size
- SLC
  - Limited information

All: no provision for AM, e.g. materials,  
internal structure

# + New format needed

- Tailor to AM community needs
  - No content constraints
- Retain Community Control
  - Not Proprietary
- Neutral
  - Avoids association with existing companies



# + Desired features

- simple
- ISO 9000-ish features like product tracking
- Interoperability within different manufacturers
- Compatible with FEA applications
- Identification of parent CAD program
- Restricted number of printings
- Support multiple shells
- Editable ASCII/Text format



# + Desired features

- Information about build orientation
- Stability/robustness
- No redundancy
- Volume validity
- Lock or encrypt the file with a password
- Ability to put a permanent 'watermark'
- Supporting geometry in native way
- Keep triangle mesh / No triangle mesh



# + Reaching consensus, adoption

- Non proprietary / open source
- Endorsement by major CAD / Manufacturers
- Use ASTM / Voting
- Backwards compatible (STL)
- Expandable, XML
- Publish for comments / discussion
- Open source software
- Conversion tools
- Limit the scope: Not a CAD model



# + Current STL



<b>Advantages</b>	<b>Disadvantages</b>
Simple	Geometry leaks
Sequential memory access*	No specified units
Portable	Unnecessary redundancy
	Incompatible with color, multiple materials, etc
	Poor scalability
*Does not require large amounts of RAM, critical in '80s	Lacks auxiliary information

# + The new proposed format

- AMF
  - Additive Manufacturing Format
  - Additive Manufacturing File



# + XML



- Meta-format: Format of formats
  - Text based
  - Easy to read/write/parse
  - Existing editing tools
  - Extensible
  - Highly compressible

Addresses needs:  
Editable / Extensible /  
Readable / Open / Non  
proprietary

- Mentioned by a number of constituents
  - E.g. Materialise
  - Based on work by J. Hiller (Cornell)



# + General Concept

- Part (objects) defined by regions and materials
  - Regions defined by triangular mesh
  - Materials defined by properties/names
- Mesh properties can be specified
  - Color
  - Tolerance
  - Texture
- Materials can be combined
  - Graded materials
  - Microstructure



# + Basic Structure

```
<?xml version="1.0"?>
<AMF>
  <Object PrintID = "0" units = "mm">
    <Mesh>
      <Vertices>
        <Vertex VertexID="0">
          <VertexLocation x="0" y="1.332" z="3.715"/>
        </Vertex>
        <Vertex VertexID="1">
          <VertexLocation x="0" y="1.269" z="3.715"/>
        </Vertex>
        ...
      </Vertices>

      <Region FillMaterialID = "0">
        <Triangle V1 = "0" V2 = "1" V3 = "3"/>
        <Triangle V1 = "0" V2 = "1" V3 = "4"/>
        ...
      </Region>
    </Mesh>
  </Object>
</AMF>
```

Addresses needs:  
Simple / Watertight /  
Backward Compatible  
(STL)



# + Compressibility

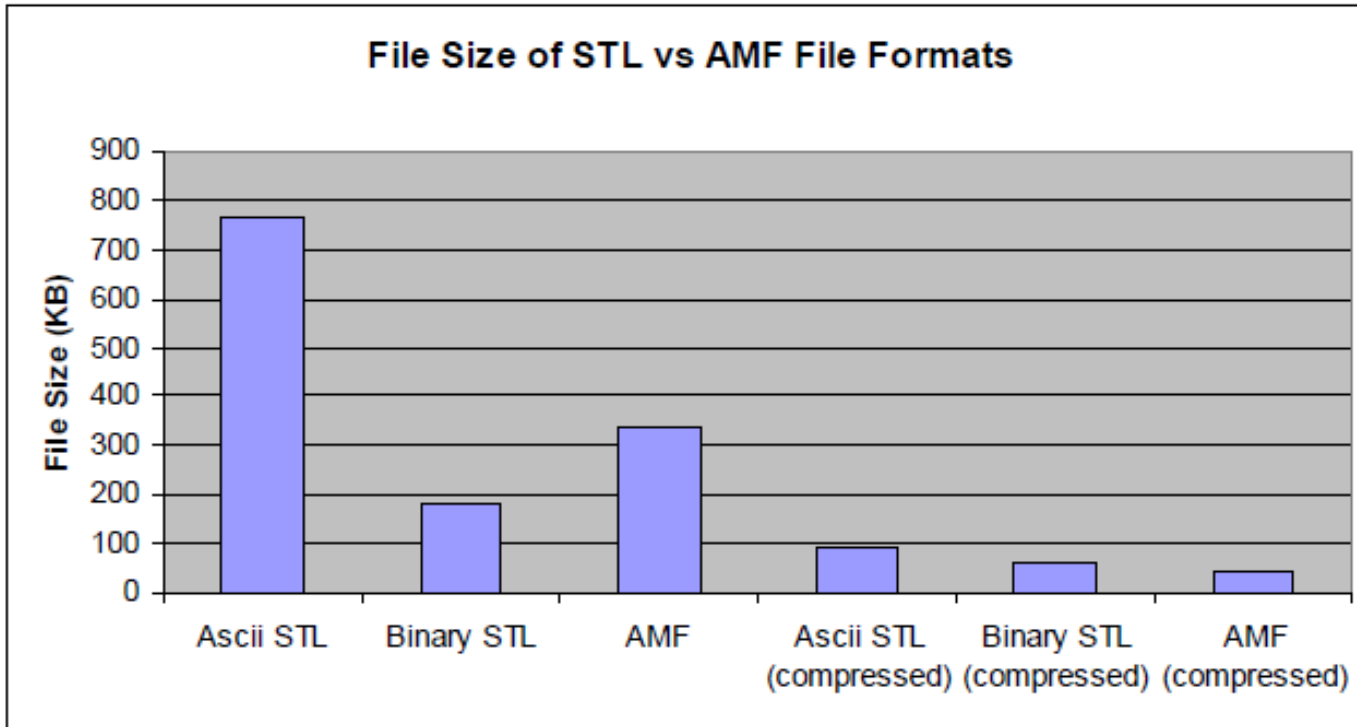

Need to look at dependency on # of digits

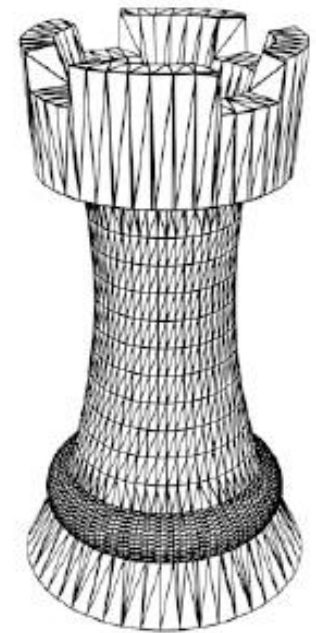

Addresses  
needs: Small /  
Compressible

# + Multiple Materials

```
<?xml version="1.0"?>
<AMF>
  <Palette>
    <Material MaterialID = "0">
      <Name>StiffMaterial</Name>
    </Material>
    <Material MaterialID = "1">
      <Name>FlexibleMaterial</Name>
    </Material>
  </Palette>

  <Object PrintID = "0" units = "mm">
    <Mesh>
      <Vertices>
        ...
      </Vertices>

      <Region FillMaterialID = "0">
        ...
      </Region>
      <Region FillMaterialID = "1">
        <Triangle V1 = "5" V2 = "6" V3 = "7"/>
        <Triangle V1 = "5" V2 = "7" V3 = "9"/>
        ...
      </Region>
    </Mesh>
  </Object>
</AMF>
```



Addresses needs:  
Multiple Materials, No  
leaks between regions  
(shared vertices)

# + Graded Materials

```
<?xml version="1.0"?>
<AMF>
  <Palette>
    <Material MaterialID = "0">
      <Name>StiffMaterial</Name>
    </Material>
    <Material MaterialID = "1">
      <Name>FlexibleMaterial</Name>
    </Material>
    <Material MaterialID = "2">
      <Name>GradientMaterial</Name>
      <Equation UseMaterialID = "0">0.30*X</Equation>
      <Equation UseMaterialID = "1">0.30*(1-X)</Equation>
    </Material>
  </Palette>

  <Object PrintID = "0" units = "mm">
    ...
  </Object>
</AMF>
```

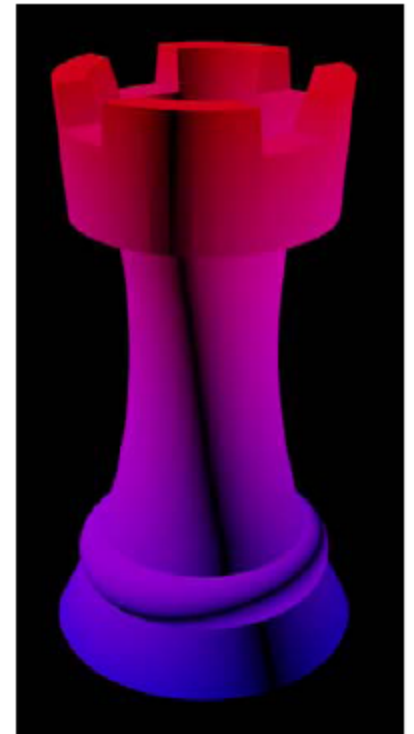

# + Microstructure

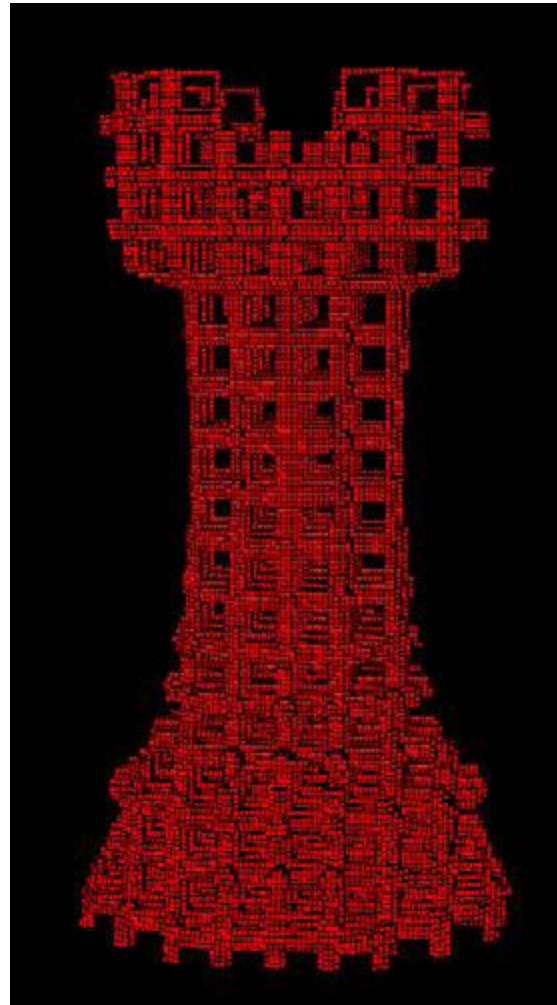

Addresses needs:  
Periodic  
meso/microstructure



# + Material properties

- By manufacturer's name
  - <Name> **ABS** </Name>
  - <Name> **Tango Black** </Name>
  - <Name> **Nylon 1234** </Name>
- By physical property
  - </Property Type="Elastic Modulus" Value="4E9">
  - </Property Type="Poisson Ratio" Value="1.2">
- External reference (URL)

Addresses needs:  
Material  
specifications/libraries

# + Color and Graphics

- By volumetric region
  - Solid color
- By vertex
  - Specify Vertex color
  - Specify Vertex coordinate in a bitmap



# + Color and Graphics

```
<?xml version="1.0"?>
<AMF>
  <Object PrintID = "0" units = "mm">
    <Mesh>
      <ColorFile MapID="0">
        <File>Logo.bmp</File>
      </ColorFile>
      <Vertices>
        <Vertex VertexID="0">
          <VertexLocation x="0" y="1.332" z="3.715"/>
          <VertexMap UseMapID="0" MapXPixel="65" MapYPixel="87"/>
        </Vertex>
        <Vertex VertexID="1">
          <VertexLocation x="0" y="1.269" z="3.715"/>
          <VertexMap UseMapID="0" MapXPixel="64" MapYPixel="87"/>
        </Vertex>
        <Vertex VertexID="2">
          <VertexLocation x="0" y="1.310" z="3.587"/>
          <VertexMap UseMapID="0" MapXPixel="32" MapYPixel="10"/>
        </Vertex>
        ...
      </Vertices>
      <Region FillMaterialID = "0">
        <Color R = "0" G = "0" B = "0.5"/>
        <Triangle V1 = "0" V2 = "1" V3 = "2"/>
        <Triangle V1 = "0" V2 = "1" V3 = "4"/>
        ...
      </Region>
    </Mesh>
  </Object>
</AMF>
```



# + Tolerances

- By volumetric region
  - Nominal tolerance
  - Allowed variation from original volume
- By vertex
  - Specify point tolerance (?)
  - Point to point

# + Non-meshed geometry?

- Other representations are not mutually exclusive

- **Voxel maps**

- For digital/inkjet microstructure

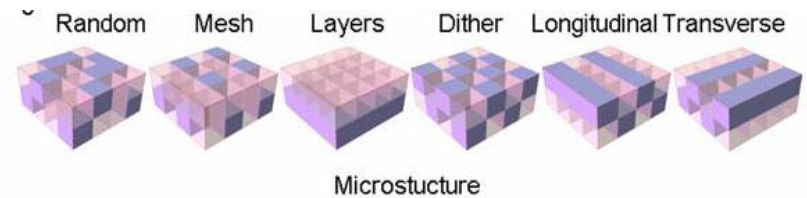

- **NURBS**

- Add slope vectors to some triangle mesh edges
- Other STEP types?

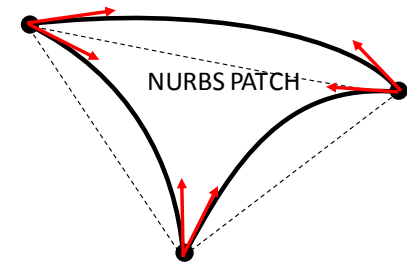
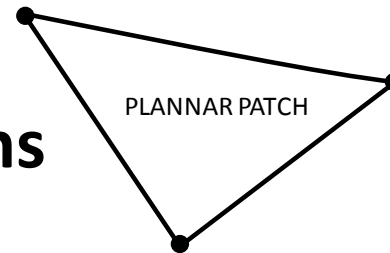

- **Functional Representations**

- implicit equations

```
<?xml version="1.0"?>
<AMF>
  <Object PrintID = "0" units = "mm">
    <FRep MaterialID = "0">
      <GeometryEquation>
        <![CDATA[X^2+Y^2+Z^2-4 <= 0 & Z >= 0]]>
      </GeometryEquation>
    </FRep>
  </Object>
</AMF>
```

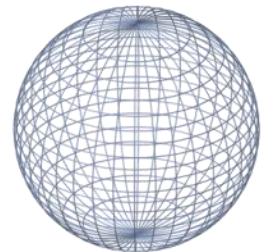

# + Nurbs patch

- Optionally add slope vectors to some triangle mesh edges to allow for very accurate geometry.
  - Perfect sphere can be made with ~20 patches

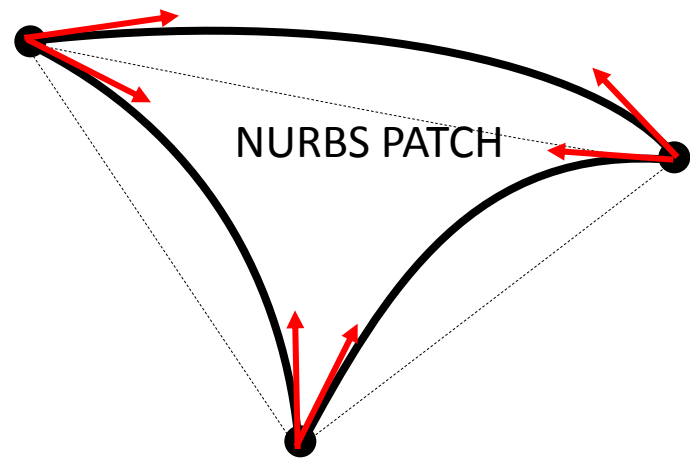
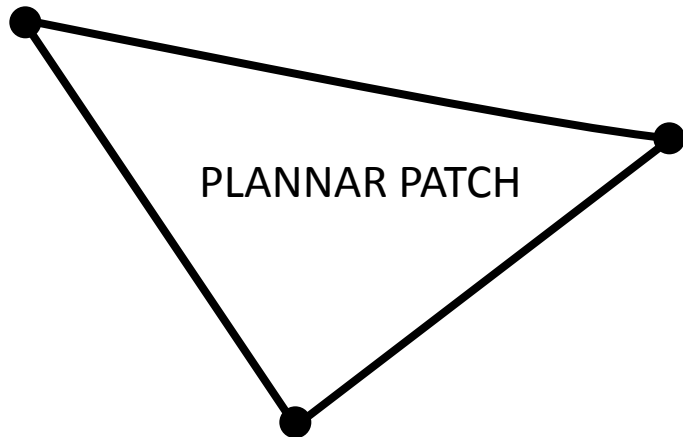

# + Print Constellation

- Print orientation
- Duplicated objects
- Sets of different objects
- Efficient nesting
- Hierarchical



# + Metadata

<Metadata>

<Datum ID="Author" Data="John Doe"></Datum>

<Datum ID="Company" Data="..."></Datum>

<Datum ID="Description" Data="..."></Datum>

<Datum ID="Originating CAD System" Data="..."></Datum>

<Datum ID="Originating CAD File" Data="..."></Datum>

<Datum ID="Comment" Data="..."></Datum>

</Metadata>

# + Encryption

<Metadata>

<Datum ID="Author" Data="John Doe"></Datum>

<Datum ID="Company" Data="..."></Datum>

<Datum ID="Description" Data="..."></Datum>

<Datum ID="Comment" Data="..."></Datum>

<Datum ID="Encryption" Data="Prompt"></Datum>

</Metadata>

```
<Mesh>
  <Vertices>
    <Vertex VertexID="0">
      <VertexLocation x="0" y="1.332" z="3.715"/>
    </Vertex>
    <Vertex VertexID="1">
      <VertexLocation x="0" y="1.269" z="3.715"/>
    </Vertex>
  </Vertices>
</Mesh>
```



# + Watermark / Copyright

<Metadata>

<Datum ID="Author" Data="John Doe"></Datum>

<Datum ID="Company" Data="..."></Datum>

<Datum ID="Description" Data="..."></Datum>

<Datum ID="Comment" Data="..."></Datum>

<Datum ID="Copyright" Data="Owner"></Datum>

</Metadata>

```
<Mesh>
  <Vertices>
    <Vertex VertexID="0">
      <VertexLocation x="0" y="1.332" z="3.715"/>
    </Vertex>
    <Vertex VertexID="1">
      <VertexLocation x="0" y="1.269" z="3.715"/>
    </Vertex>
```

# + Other features

- URL can be used in lieu of material data to allow for external libraries
- Validation checksums
  - E.g. Original vs. actual part/region volumes
- Automatic error checking
  - Readers/writers must check for intact topology, e.g.
    - All nodes referenced by at least 3 triangles
    - All edges referenced exactly twice per region



# + ISO STANDARD

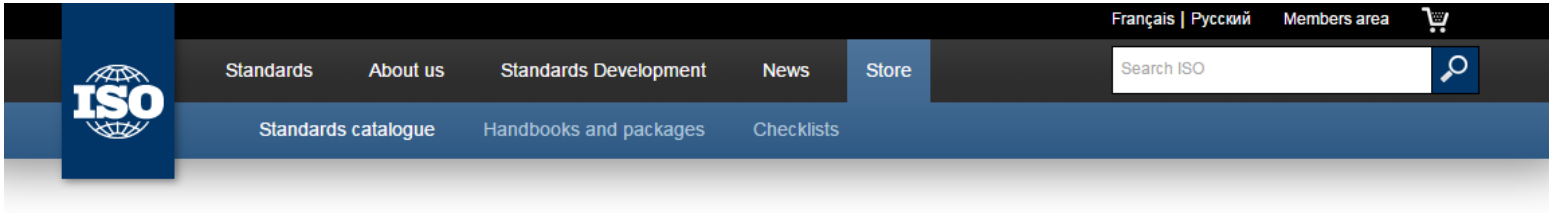

ISO Store > Store > Standards catalogue > By TC > ISO/TC 261 Additive manufacturing

## ISO/ASTM 52915:2013 <sup>®</sup>

Standard specification for additive manufacturing file format (AMF) Version 1.1

### Abstract

[Preview ISO/ASTM 52915:2013](#)

ISO/ASTM 52915:2013 describes a framework for an interchange format to address the current and future needs of additive manufacturing technology. For the last three decades, the STL file format has been the industry standard for transferring information between design programs and additive manufacturing equipment. An STL file contains information only about a surface mesh and has no provisions for representing color, texture, material, substructure, and other properties of the fabricated target object. As additive manufacturing technology is quickly evolving from producing primarily single-material, homogenous shapes to producing multimaterial geometries in full colour with functionally graded materials and microstructures, there is a growing need for a standard interchange file format that can support these features.

General information

Revisions

Corrigenda / Amendments

**Document published on:** 2013-06-01

**Edition:** 1 (Monolingual)

**ICS:** 35.240.50; 25.040.20

**Status:** ✓ Published

**Stage:** 90.92 (2014-09-17)

**TC/SC:** ISO/TC 261

**Number of Pages:** 15

FORMAT ? LANGUAGE

✓ PDF English ▾

PAPER English ▾

CHF **88** Add to basket

#### Keep up to date with ISO

Sign up to our newsletter for the latest news, views and product information

**Subscribe**

#### Got a question?

[Check out our FAQs](#)

Email customer services